



**Doers Window
MANUFACTURING**
4901 Oak Fair Blvd., Tampa, FL 33610

9500-3 Slider XOX

IMPACT RATED - HVHZ
w/ Nailing Fin

GENERAL NOTES

1. This product anchoring drawing has been evaluated and is in compliance with the 5th Edition (2014) Florida Building Code (FBC) including the "High Velocity Hurricane Zone" (HVHZ). See the Certification Agency Certificate for sizes, specifications & ratings.
2. Product anchors shall be as listed and spaced as shown on details. Anchor embedment to base material shall be beyond wall dressing or stucco.
3. When used in the "HVHZ, this product complies with Section 1626 of the FBC and does not require an impact resistant covering.
4. Site conditions that deviate from the details of this drawing require further engineering analysis by a licensed engineer or registered architect.

TABLE OF CONTENTS

SHEET#	DESCRIPTION
1	Typical elevations, design pressures & general notes
2	Vertical & horizontal cross sections
3	Vertical & horizontal cross sections
4	Buck & frame anchoring
5	Components
6	Bill of materials and glazing details

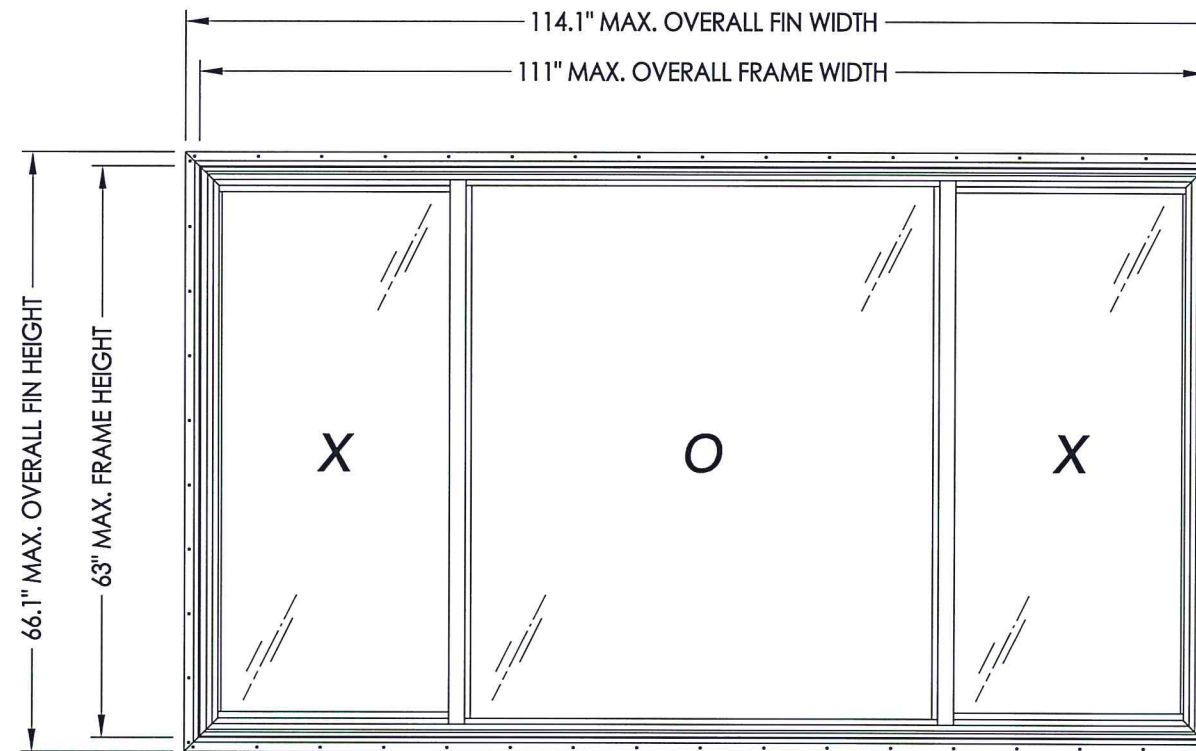

MAX. OVERALL FIN DIMENSION	MAX. OVERALL FRAME DIMENSION	MAX DAY LITE DIMENSION (OPERABLE)	MAX DAY LITE DIMENSION (FIXED)	GLASS TYPE	DESIGN PRESSURE (PSF)	
					POS.	NEG.
114.1" X 66.1"	111.0" X 63.0"	25.0" X 57.25"	51.0" X 58.5"	G1 (Fixed) G2 (Operable)	+50.0	-55.0

Note: This product is not approved for use above 30 feet in the "HVHZ".

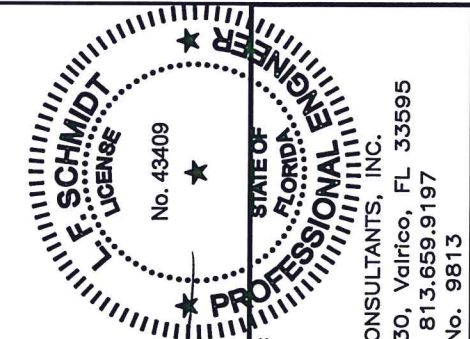

Documents Prepared By:
Lyndon F. Schmidt
P.E. No. 43409

R.W.
BUILDING CONSULTANTS, INC.
P.O. Box 230, Valrico, FL 33595
Phone No.: 813.659.9197
FBPE C.A. No. 9813

PRODUCT: Doers
PART OR ASSEMBLY:
TYPICAL ELEVATION, DESIGN
PRESSURES & GENERAL NOTES

NO.	DATE	REVISIONS
1	6/25/15	UPDATE TO 5TH ED. (2014) FBC

DATE: 9/24/14
SCALE: N.T.S.
DWG. BY: JK
CHK. BY: LFS
DRAWING NO.:
FL-16853.11
SHEET 1 OF 6

- Note:
1. Lock and keeper located 7" from each end of lock/meeting stile.
 2. Metal roller assembly located 2" from each end of the bottom rail.
 3. Anti-lift secured to head with (6) #6 x 1/2" PPH SMS.

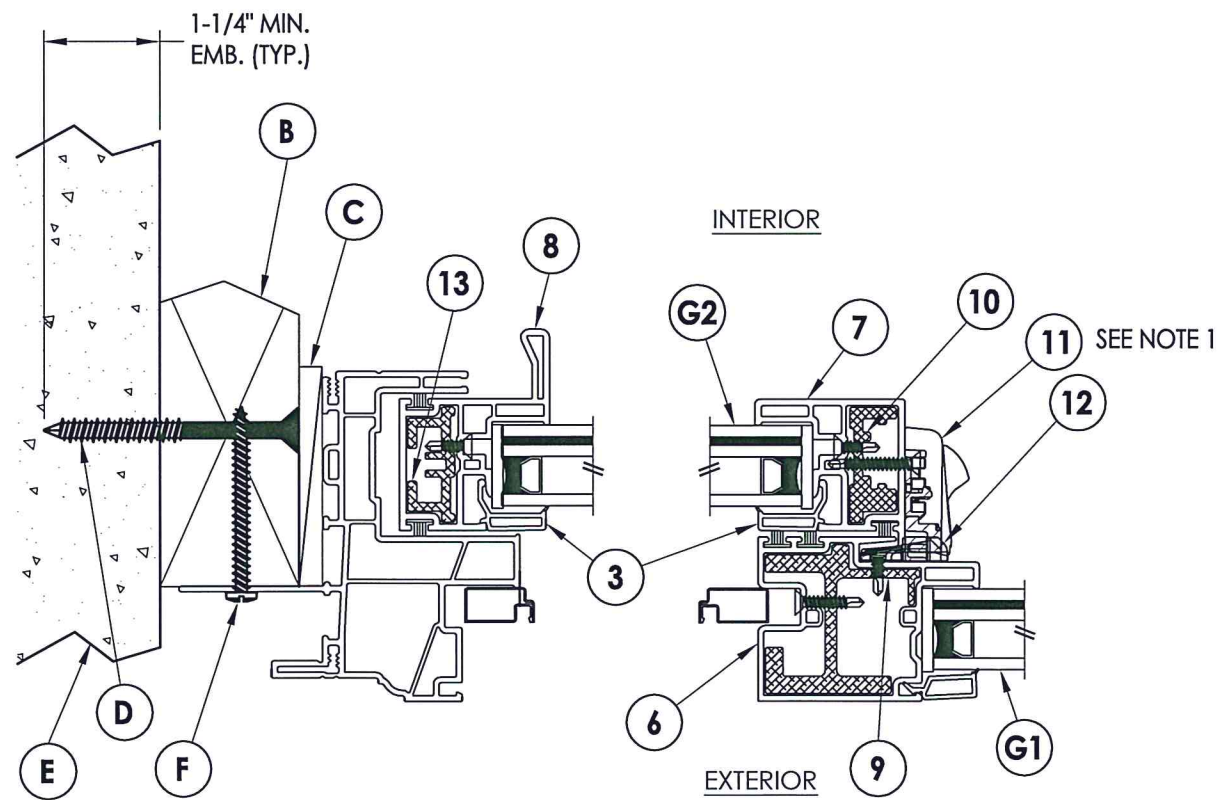
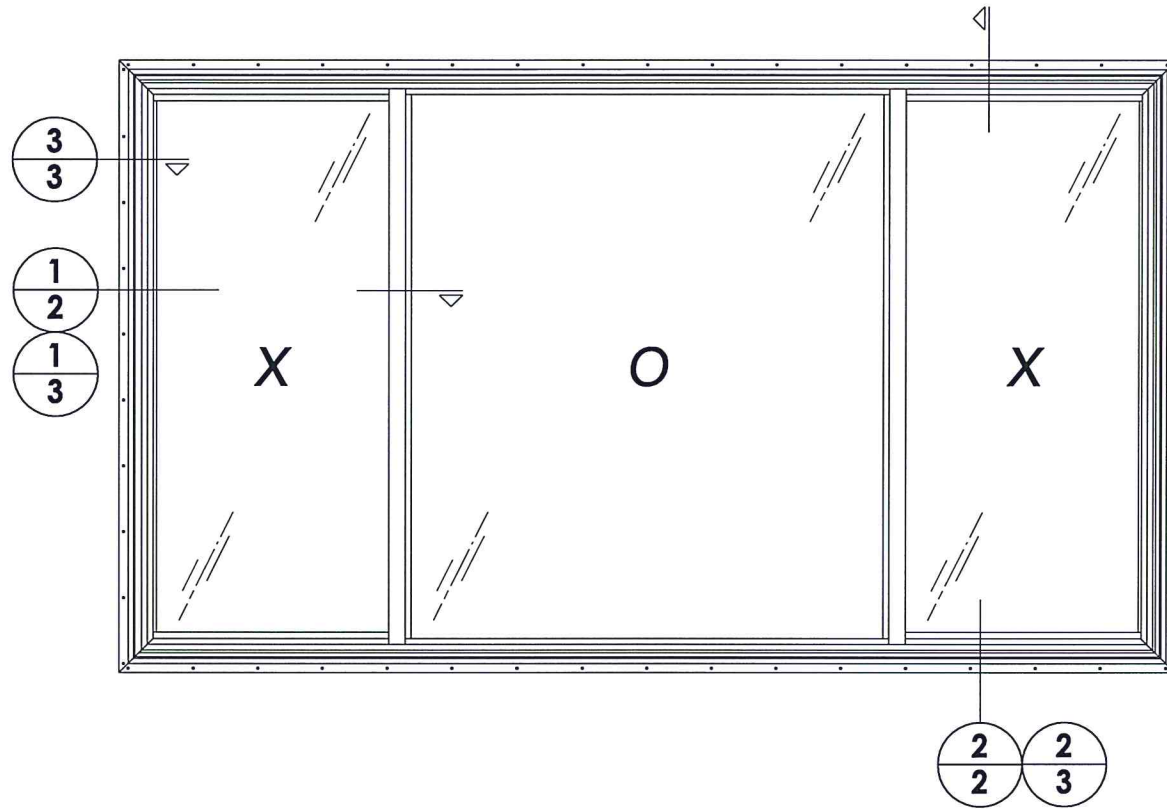

1 HORIZONTAL CROSS SECTION
2 2X Buck Masonry Construction

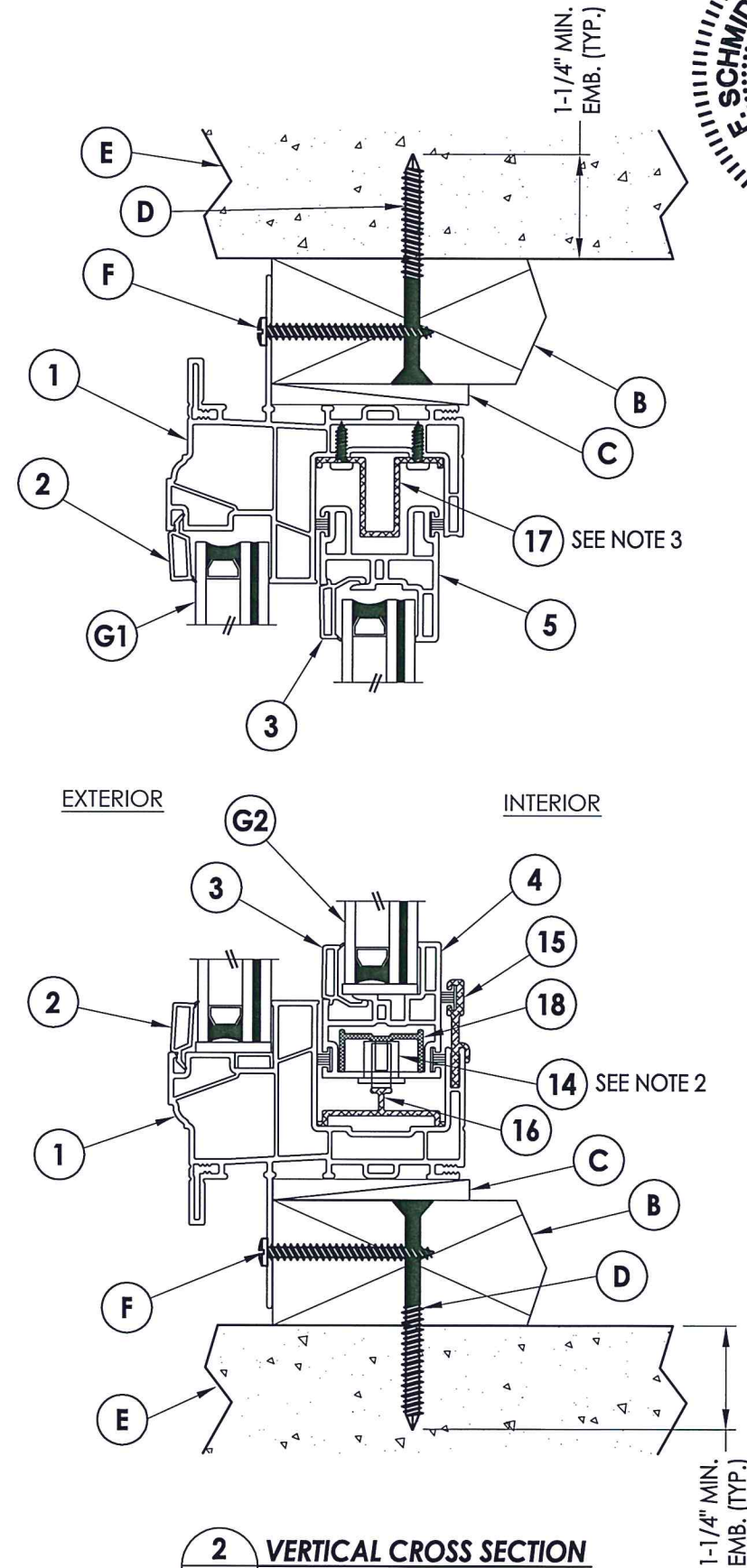

2 VERTICAL CROSS SECTION
2 2X Buck Masonry Construction

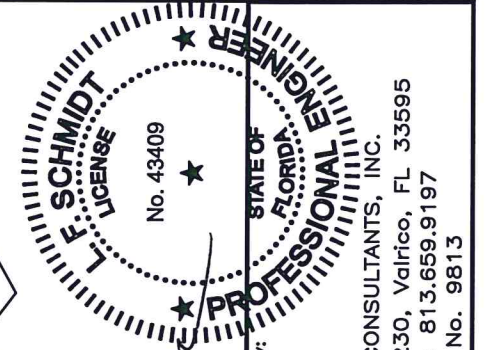

Documents Prepared By:
 Lyndon F. Schmidt
 P.E. No. 43409

RW BUILDING CONSULTANTS, INC.
 P.O. Box 230, Valrico, FL 33595
 Phone No.: 813.659.9197
 FBPE C.A. No. 9813

PRODUCT: Doers

PART OR ASSEMBLY: VERTICAL & HORIZONTAL CROSS SECTIONS

NO.	DATE	BY
1	6/25/15	LFS
		FBC

REVISIONS

DATE: 9/24/14
 SCALE: N.T.S.
 DWG. BY: JK
 CHK. BY: LFS
 DRAWING NO.: FL-16853.11
 SHEET 2 OF 6

R:\Clients\Doers PERMANENTVA - Florida Product Approvals\FL-16853 Windows - Horizontal Sliders\C - Drawings\FL-16853 (2014)\FL-16853.7-12.dwg, 3.11

- Note:
1. Lock and keeper located 7" from each end of lock/meeting stile.
 2. Metal roller assembly located 2" from each end of the bottom rail.
 3. Anti-lift secured to head with (6) #6 x 1/2" PPH SMS.

NOTE: Sheet Metal Screws must penetrate a min. of 3 threads through metal (maintain a min. 3/8" edge distance).

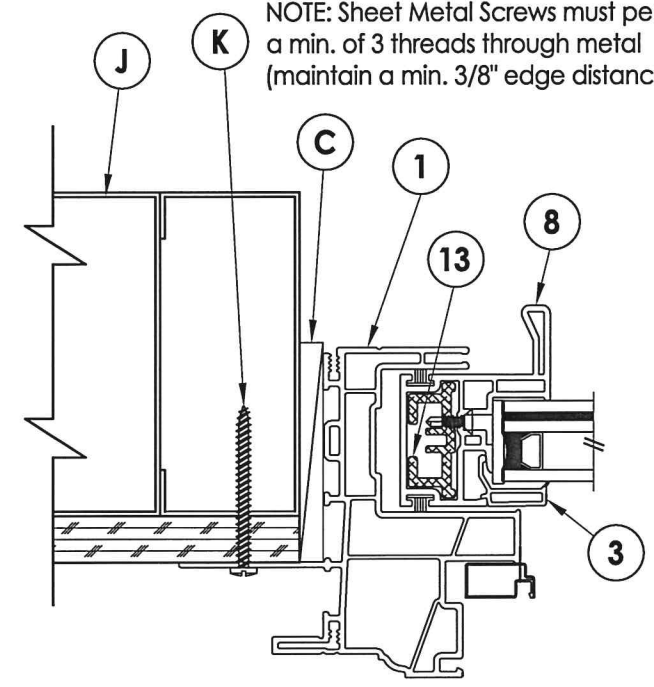

3 HORIZONTAL CROSS SECTION
3 Shown w/ Steel Stud Framing Option

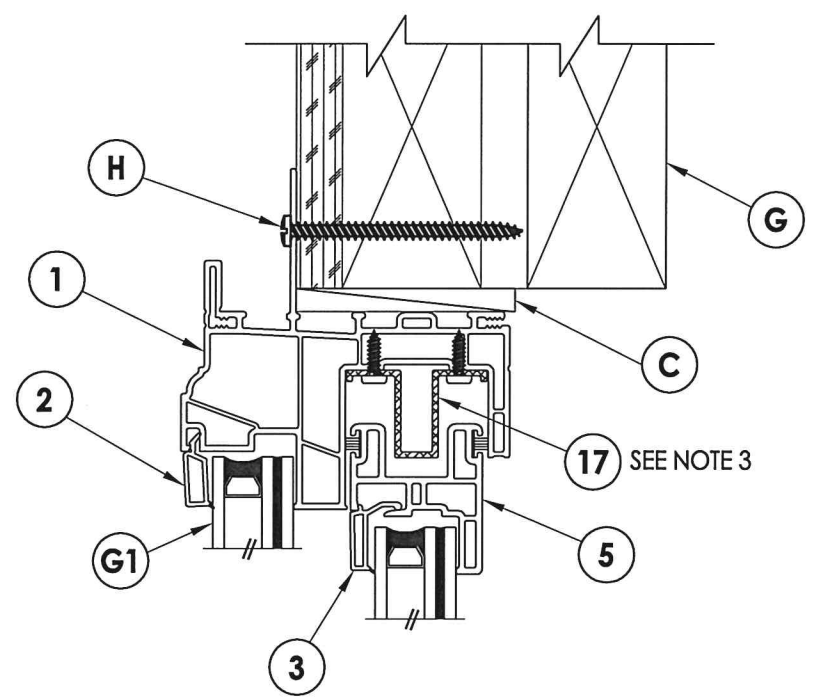

EXTERIOR INTERIOR

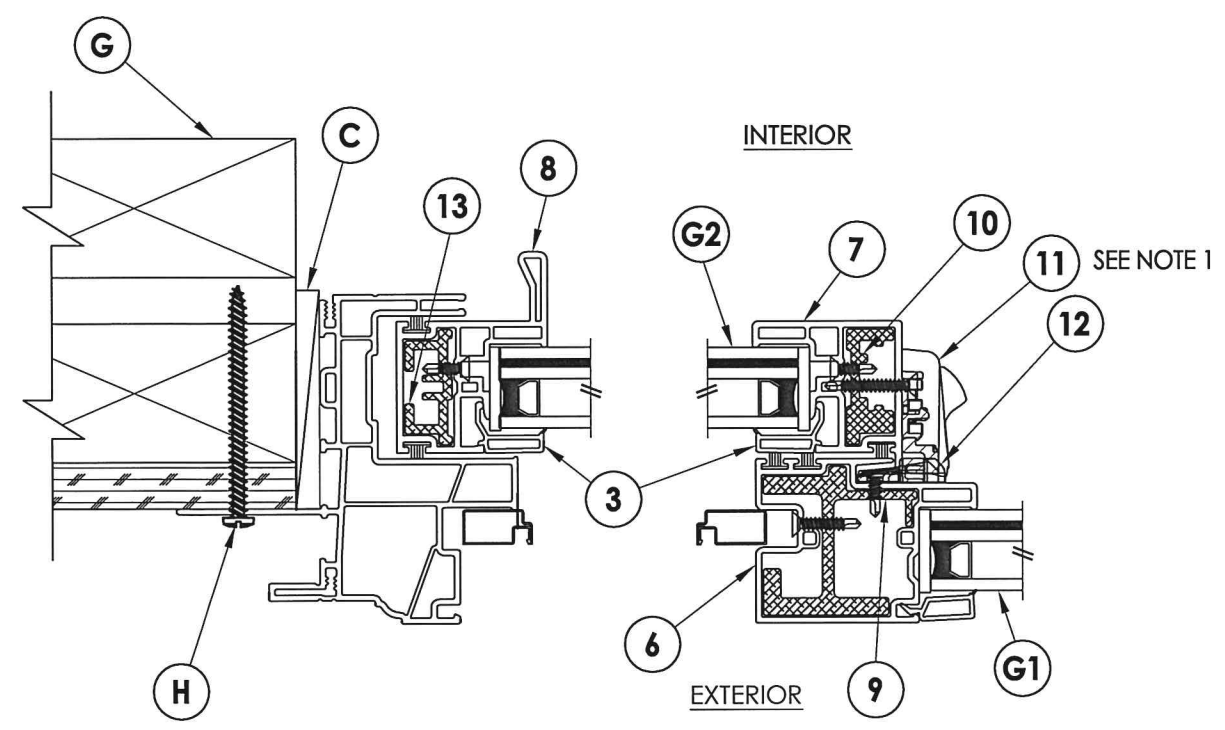

1 HORIZONTAL CROSS SECTION
3 2X Stud Construction

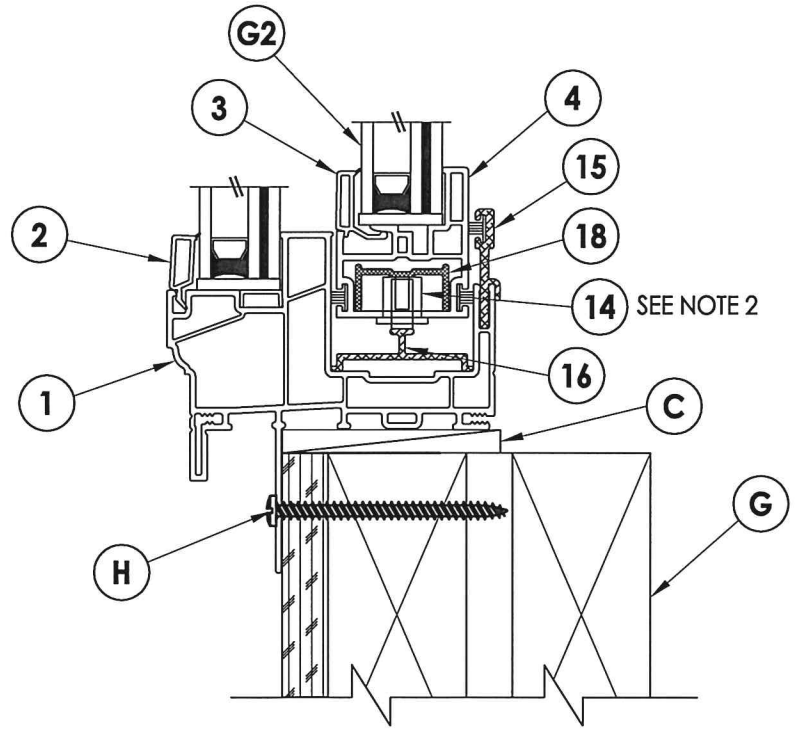

2 VERTICAL CROSS SECTION
3 2X Stud Construction

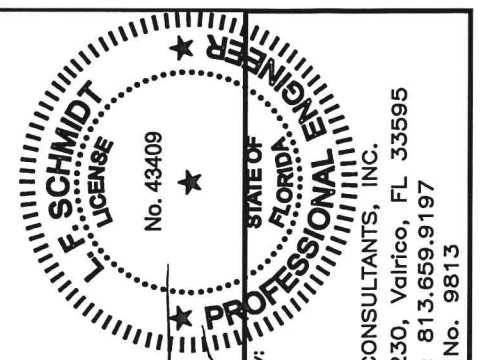

Documents Prepared By:
Lyndon F. Schmidt
P.E. No. 43409

RW BUILDING CONSULTANTS, INC.
P.O. Box 230, Valrico, FL 33595
Phone No.: 813.659.9197
FBPE C.A. No. 9813

PRODUCT:	Doers	
PART OR ASSEMBLY:	VERTICAL & HORIZONTAL CROSS SECTIONS	
NO.	DATE	BY
1	6/25/15	LFS
		FBC
		BY
REVISIONS		
DATE:	9/24/14	
SCALE:	N.T.S.	
DWG. BY:	JK	
CHK. BY:	LFS	
DRAWING NO.:	FL-16853.11	
SHEET	3	OF 6

R:\Clients\Doers PERMANENT Florida Product Approvals\FL-16853 Windows - Horizontal Sliders\C - Drawings\FL-16853 (2014)\FL-16853.7-12.dwg, 4.11

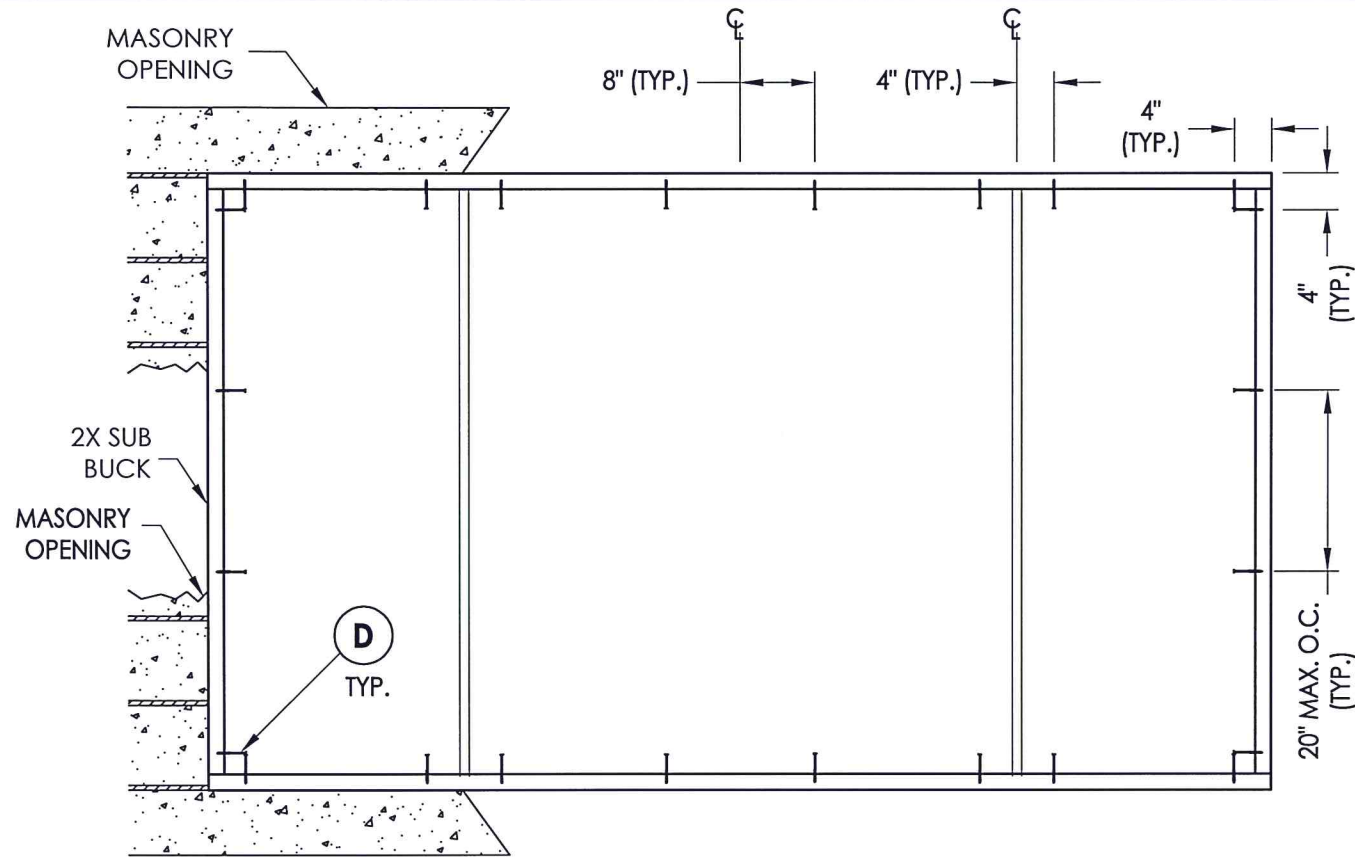

BUCK ANCHORING

2X/STEEL STUD FRAMING TO BE DESIGNED BY THE ENGINEER OR ARCHITECT OF RECORD BASED ON WIND LOADS AND THE CLADDING BEING USED.

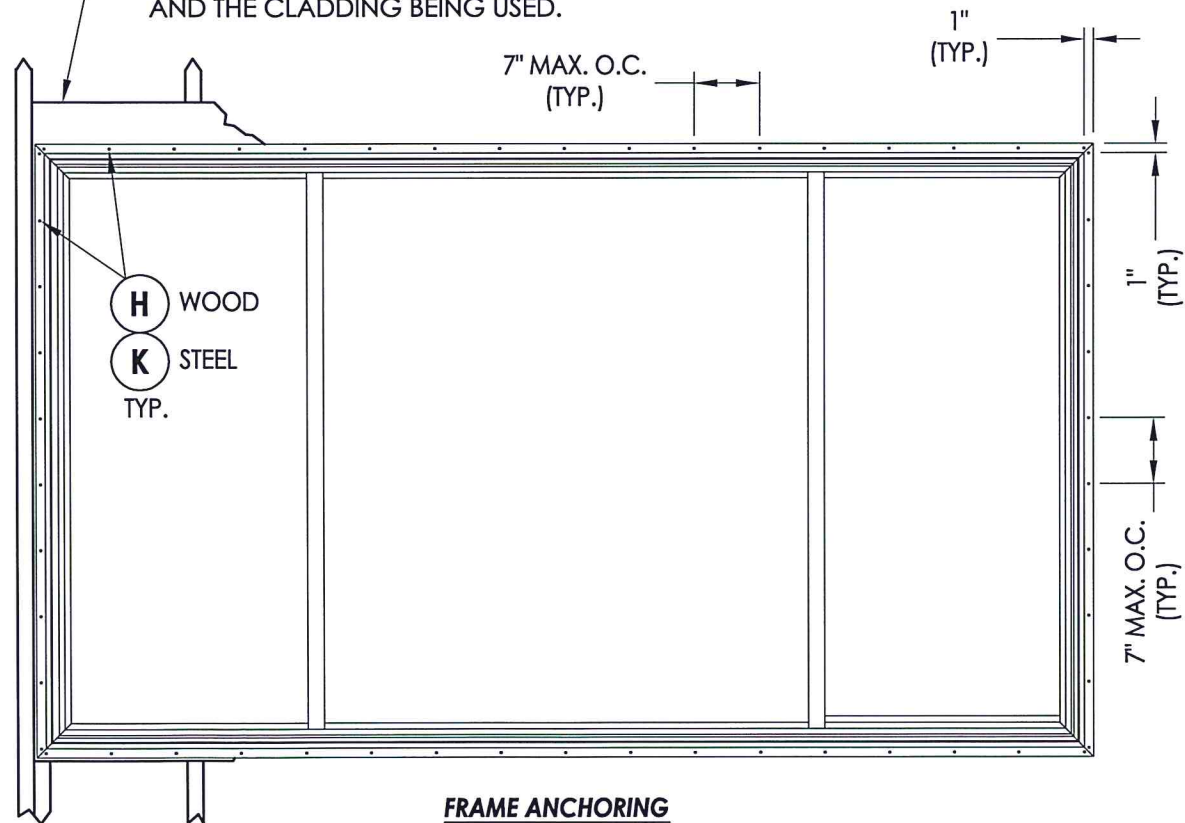

FRAME ANCHORING
Stud Construction

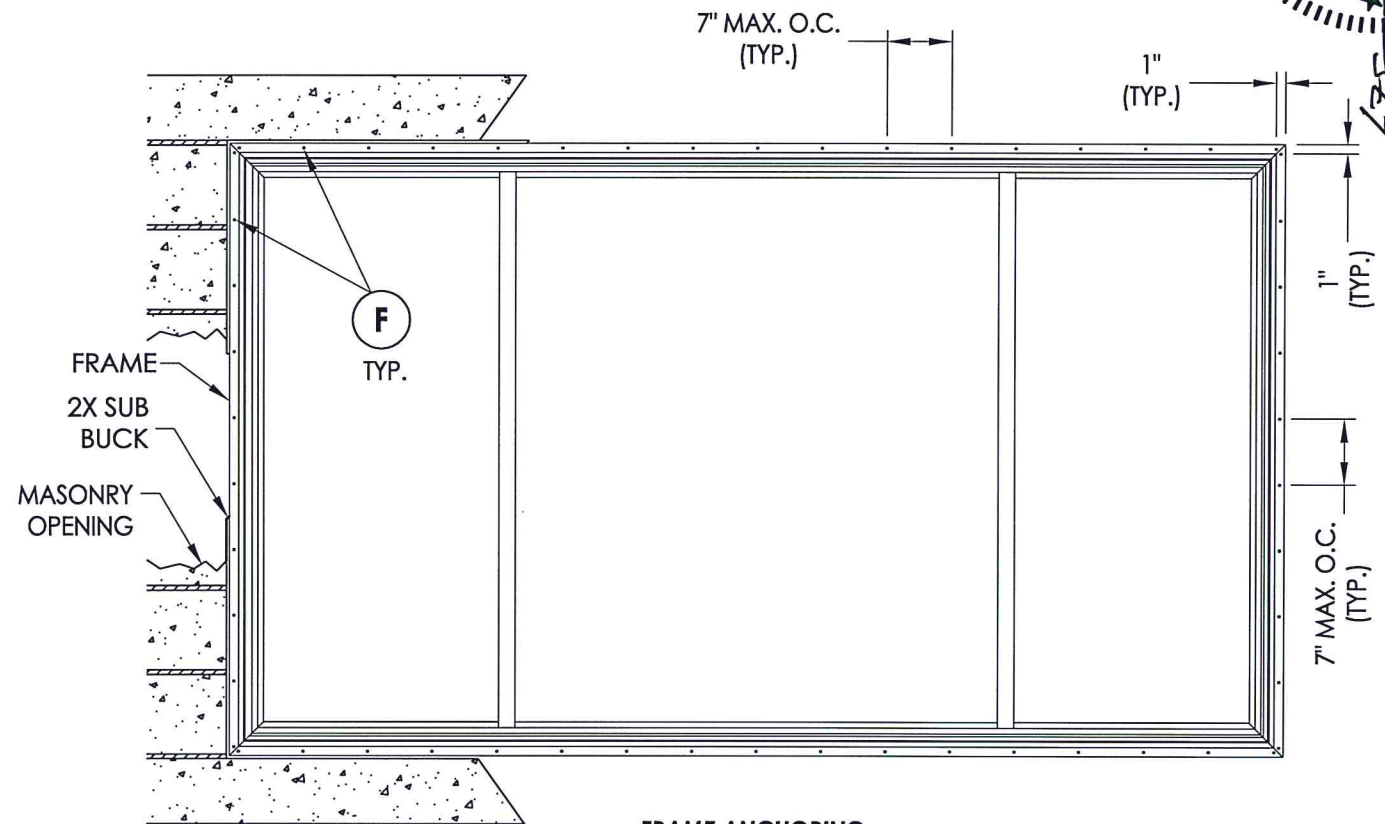

FRAME ANCHORING
2X Buck Masonry Construction

CONCRETE ANCHOR NOTES:

- Concrete anchor locations at the corners may be adjusted to maintain the min. edge distance to mortar joints.
- Concrete anchor locations noted as "MAX. ON CENTER" must be adjusted to maintain the min. edge distance to mortar joints, additional concrete anchors may be required to ensure the "MAX. ON CENTER" dimension are not exceeded.
- Concrete anchor table:

ANCHOR TYPE	ANCHOR SIZE	MIN. EMBEDMENT	MIN. CLEARANCE TO MASONRY EDGE	MIN. CLEARANCE TO ADJACENT ANCHOR
ITW TAPCON®	1/4"	1-1/4"	2"	4"
ELCO ULTRACON®	1/4"	1-1/4"	1"	4"

WOOD SCREW INSTALLATION NOTES:

- Maintain a minimum 5/8" edge distance, 1" end distance, & 1" o.c. spacing of wood screws to prevent the splitting of wood.

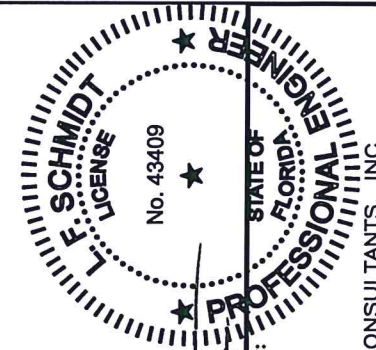

Documents Prepared By:
Lyndon F. Schmidt
P.E. No. 43409

R.W. BUILDING CONSULTANTS, INC.
P.O. Box 230, Valrico, FL 33595
Phone No.: 813.659.9197
FBPE C.A. No. 9813

PRODUCT: Doers
PART OR ASSEMBLY: BUCK & FRAME ANCHORING

NO.	DATE	BY	REVISIONS
1	6/25/15	LFS	UPDATE TO 5TH ED. (2014) FBC

DATE: 9/24/14
SCALE: N.T.S.
DWG. BY: JK
CHK. BY: LFS
DRAWING NO.: FL-16853.11
SHEET 4 OF 6

C:\Clients\Doers PERMANENT\Florida Product Approvals\FL-16853 Windows - Horizontal Sliders\C - Drawings\FL-16853 (2014)\FL-16853.7-12.dwg, 5.11

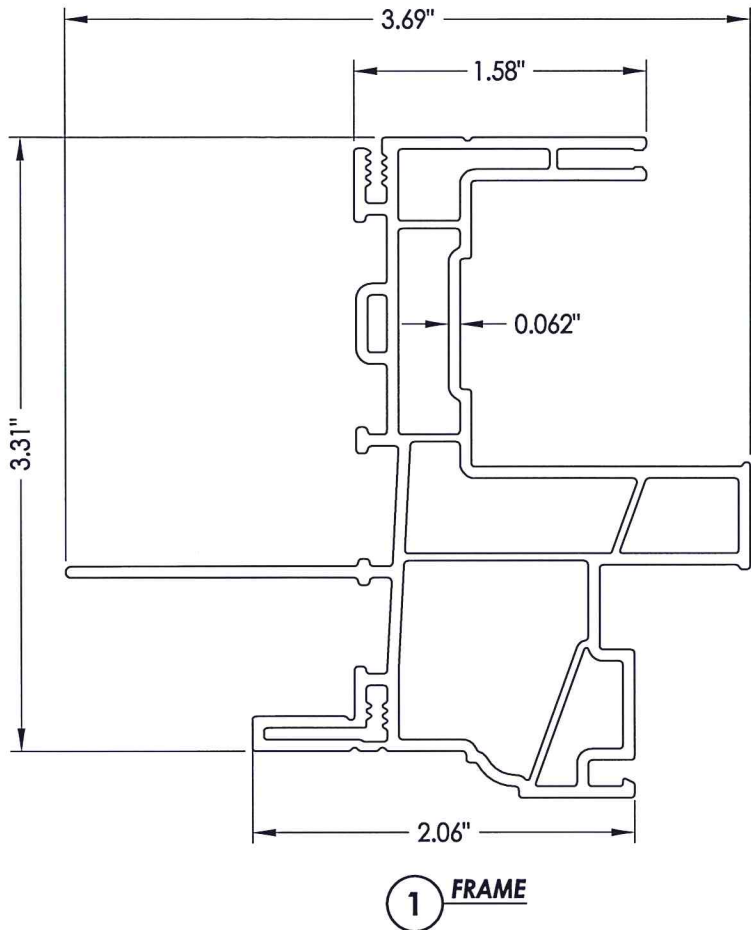

1 FRAME

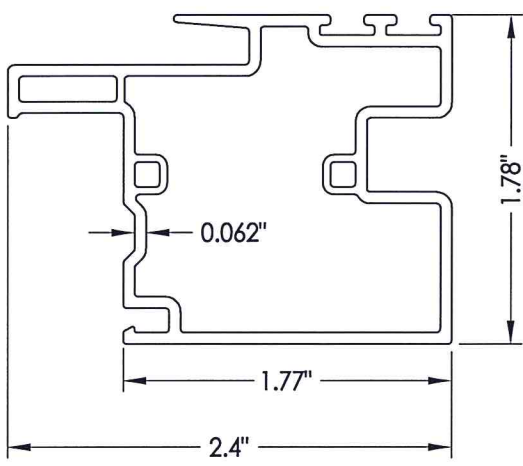

6 MEETING STILE

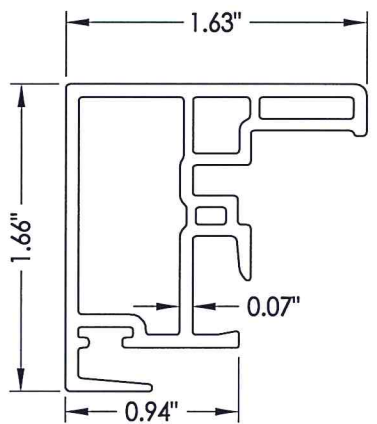

7 LOCK STILE

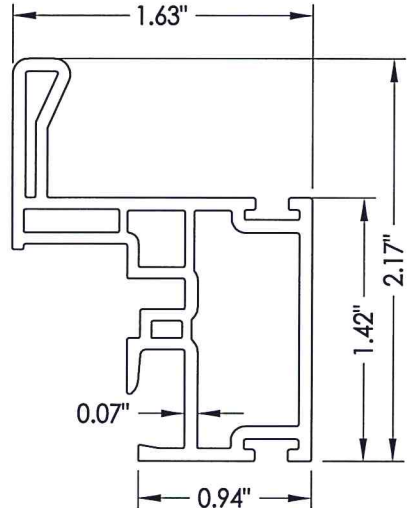

8 HANDLE STILE

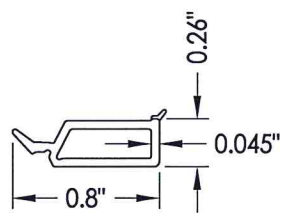

2 GLAZING BEAD

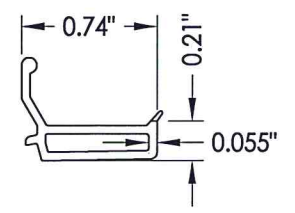

3 GLAZING BEAD

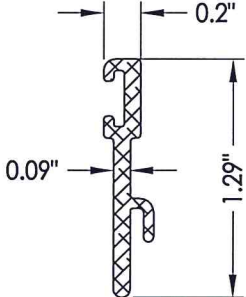

15 SILL RISER

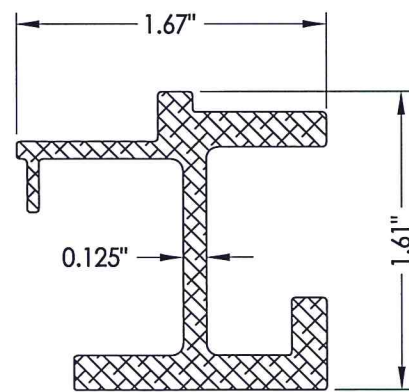

9 MEETING STILE REINFORCEMENT

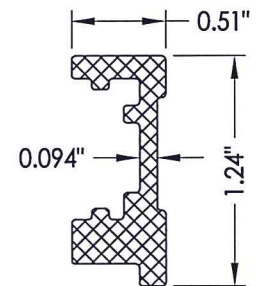

10 LOCK STILE REINFORCEMENT

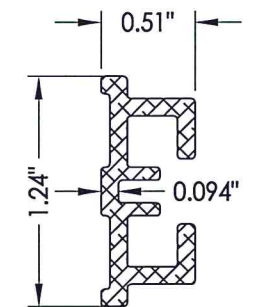

13 HANDLE STILE REINFORCEMENT

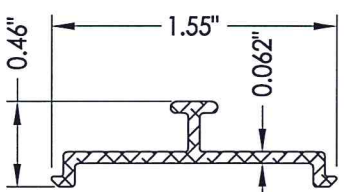

16 ROLLER TRACK

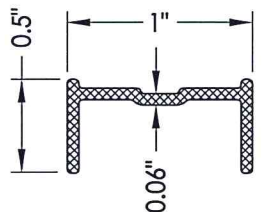

18 BOTTOM RAIL REINFORCEMENT

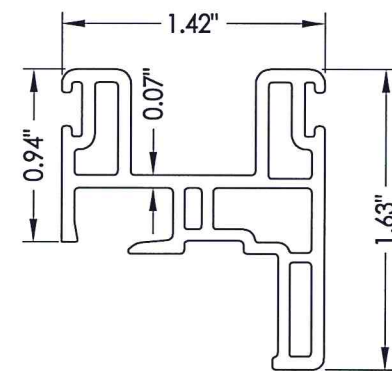

5 TOP RAIL

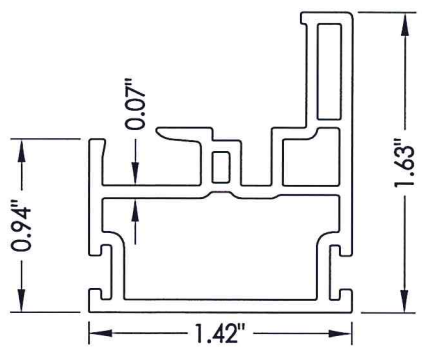

4 BOTTOM RAIL

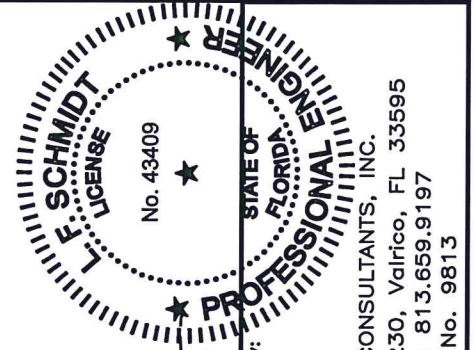

Documents Prepared By:
Lyndon F. Schmidt
P.E. No. 43409

RW BUILDING CONSULTANTS, INC.
P.O. Box 230, Valrico, FL 33595
Phone No.: 813.659.9197
FBPE C.A. No. 9813

PRODUCT: Doers		PART OR ASSEMBLY: COMPONENTS	
NO.		DATE	
1		6/25/15	
DATE		BY	
LFS		FBC	
UPDATE TO 5TH ED. (2014)		LFS	
DATE: 9/24/14			
SCALE: N.T.S.			
DWG. BY: JK			
CHK. BY: LFS			
DRAWING NO.: FL-16853.11			
SHEET 5 OF 6			

R:\Clients\Doers PERMANENT\Florida Product Approvals\FL-16853 Windows - Horizontal Sliders\C - Drawings\FL-16853 (2014)\FL-16853.7-12.dwg, 6.11

BILL OF MATERIALS

ITEM #	DESCRIPTION	MATERIAL
B	2X BUCK (SG >= 0.55)	WOOD
C	1/4" MAX. SHIM SPACE	-
D	1/4" X 2-3/4" PFH ELCO OR ITW CONCRETE SCREW	STEEL
E	MASONRY - 3,000 PSI MIN. CONCRETE CONFORMING TO ACI 301 OR HOLLOW BLOCK CONFORMING TO ASTM C90	CONCRETE
F	#10 X 2" PPH SMS (1-3/4" MIN. EMBEDMENT)	STEEL
G	2X STUD (SG >= 0.55)	WOOD
H	#10 X 2-1/2" PPH SMS (1-3/4" MIN. EMBEDMENT)	STEEL
J	STEEL STUD Min. Thk .033" (ASTM A653 GRADE 33 Fy=33 ksi min., Fu=45 ksi min.)	STEEL
K	#10 PPH SELF-DRILLING SMS	STEEL
1	EXTRUDED VINYL FRAME (437)*	RIGID PVC
2	EXTRUDED VINYL GLAZING BEAD (736A)*	RIGID PVC
3	EXTRUDED VINYL GLAZING BEAD (425A)*	RIGID PVC
4	BOTTOM RAIL (424B)*	RIGID PVC
5	TOP RAIL (478)*	RIGID PVC
6	MEETING STILE (477)*	RIGID PVC
7	LOCK STILE (476)*	RIGID PVC
8	HANDLE STILE (475B)*	RIGID PVC
9	MEETING STILE REINFORCEMENT	6063-T5 ALUM
10	LOCK STILE REINFORCEMENT	6063-T5 ALUM
11	SASH LOCK	-
12	KEEPER	-
13	HANDLE STILE REINFORCEMENT	6063-T5 ALUM
14	ROLLER (TRUTH #2433-1000)	-
15	SILL RISER	6063-T5 ALUM
16	ROLLER TRACK	6063-T5 ALUM
17	ANTI-LIFT ALUMINUM	6063-T5 ALUM
18	BOTTOM RAIL REINFORCEMENT	6063-T5 ALUM
20	WEATHERSTRIP (.187" X .290")	-

* THE APPROVED WHITE RIGID PVC EXTERIOR EXTRUSIONS FOR WINDOWS ARE TO BE PRODUCED BY EXTRUDERS LICENSEES IN "AAMA CERTIFICATION PROGRAMS FOR RIGID PVC EXTRUSIONS".

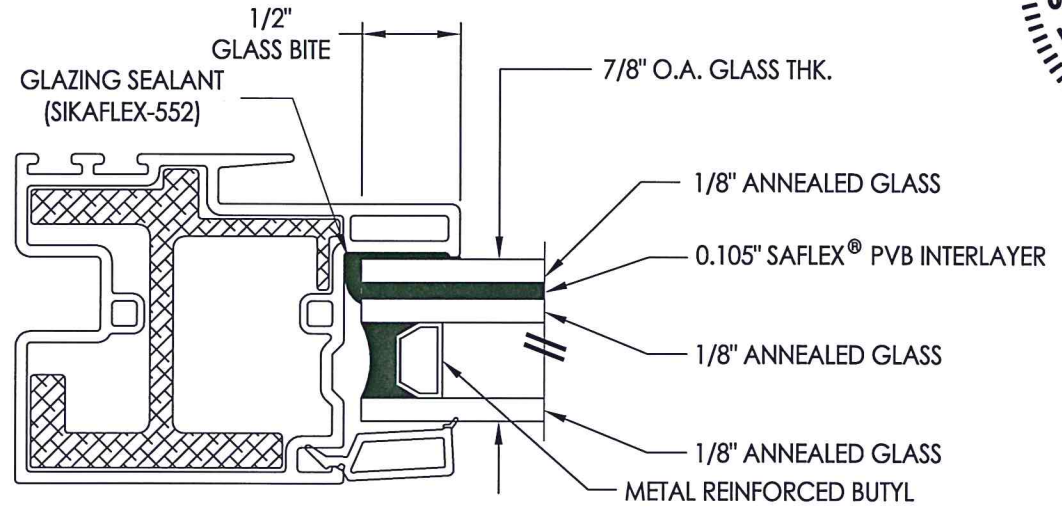

G1 **GLAZING DETAIL**
Fixed Lite

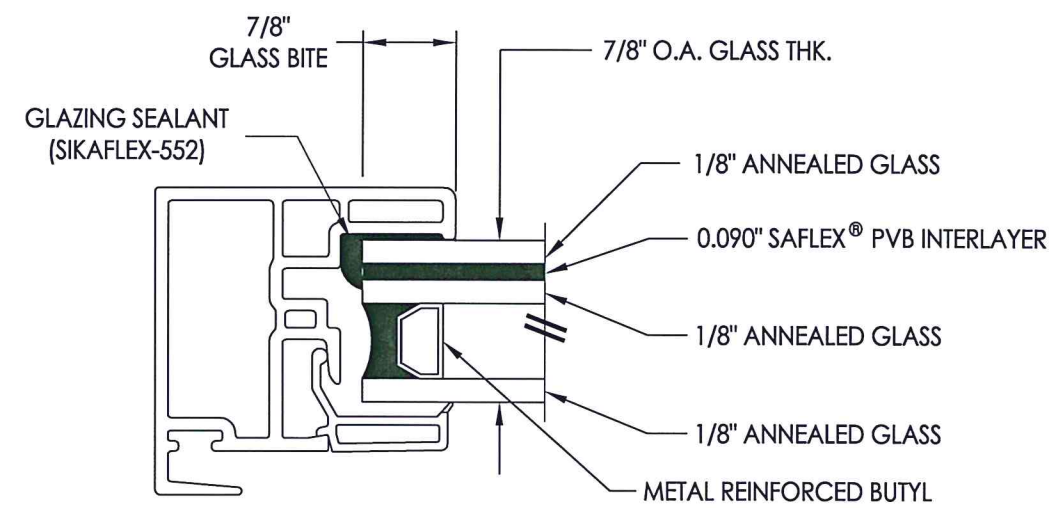

G2 **GLAZING DETAIL**
Operable Lite

F. SCHMIDT
LICENSE No. 43409
STATE OF FLORIDA
PROFESSIONAL ENGINEER

Documents Prepared By: **Lyndon F. Schmidt**
P.E. No. 43409

R.W. BUILDING CONSULTANTS, INC.
 P.O. Box 230, Valrico, FL 33595
 Phone No.: 813.659.9197
 FBPE C.A. No. 9813

PRODUCT:	Doers	
PART OR ASSEMBLY:	BILL OF MATERIALS AND GLAZING DETAILS	
NO.	DATE	BY
1	6/25/15	FBC
REVISIONS		
DATE:	9/24/14	
SCALE:	N.T.S.	
DWG. BY:	JK	
CHK. BY:	LFS	
DRAWING NO.:	FL-16853.11	
SHEET	6	OF 6